

Report Of:

- **2024 British Columbia Building Code – Part 9**
- **2023 National Building Code Alberta Edition – Part 9**
- **2020 National Building Code of Canada – Part 9**

⚠ WARNING No representation or warranty is given that your particular application of these products complies with relevant building codes or that the fasteners provided or used are appropriate for your application. Consult with professionals and local building officials before beginning work: (i) to ensure compliance with relevant building codes for your application and for your proposed use of fasteners; (ii) to ensure the integrity of the structural components in connection with which these products are to be used; (iii) to identify appropriate safety gear that is to be used during installation such as a safety harness when working above ground; (iv) to ensure that the work area is free from utilities, services and hazards; and (v) to clarify any instructions or warnings that may not be clear. Work in a safe manner wearing protective gear such as gloves, eyewear, headwear, footwear and clothing. When using tools comply with operation manuals and instructions. Metal and glass may have sharp edges and could fragment or splinter during or as a result of handling or cutting. Do not use these products in connection with any substance that is or may be harmful or corrosive to the products. Inspect and maintain these products and the structural components that they are used in connection with on a regular basis, using professionals when appropriate.

Peak® Cable Railing System
Engineering Review for Compliance with
Part 9 of
British Columbia Building Code 2024,
National Building Code Alberta Edition 2023,
And
National Building Code of Canada 2020

Peak Products Manufacturing Inc.
www.peakproducts.com

Submitted February 14, 2024 by
RDH Building Science Inc.
4333 Still Creek Drive #400
Burnaby BC V5C 6S6

BC PTP # 1003380



PERMIT TO PRACTICE RDH BUILDING SCIENCE INC.	
RM SIGNATURE:	<u>D. Vadoz</u>
RM APEGA ID #:	116145
DATE:	2024-03-22
PERMIT NUMBER: P012367 The Association of Professional Engineers and Geoscientists of Alberta (APEGA)	



Contents

1	Overview	1
1.1	Rail Elements	1
1.2	Connectors	2
2	Infill Elements	2
2.1	Stainless steel Cable	2
3	Rail Elements	2
3.1	General Rail Elements	2
4	Connectors	3
4.1	General Connectors	3
5	Results	3
6	Conclusion	4

Appendices

Appendix A List of Components

Appendix B Assembly Drawings



1 Overview

The Peak® Cable Railing System is designed to function as an interior and exterior guard within areas described below to protect the occupant from a fall. The objectives were to complete a structural review of the structural components based in Limit States Design, in accordance with applicable material standards and Part 9 of the British Columbia Building Code 2024, National Building Code Alberta Edition 2023, and the National Building Code of Canada 2020.

The Peak® Cable Railing System can only be used as a guard at locations that conform to all of the following:

- Within a single-family dwelling unit, within houses with a secondary suite including their common spaces, and for exterior guard serving no more than 2 dwelling units.
- At locations with difference in elevation of less than 4.2m between the walking surface and the adjacent surface.

The following specified loads apply for the guard:

- Concentrated load of 1 kN applied in a horizontal direction at any point along the top of guard.
- Uniformly distributed load of 0.5 kN/m applied in a horizontal direction along the top of the guard.
- Uniformly distributed vertical load of 1.5 kN/m applied along the top of the guard.
- Concentrated infill load of 0.5 kN applied anywhere within the guard.
- Uniform wind load of 1.0 kPa applied anywhere within the guard.

The following specified loads apply for the stair handrail:

- Concentrated load of 1 kN applied in a horizontal direction at any point along the top of guard.
- Concentrated load of 0.9 kN applied in any direction at any point along the top of the handrail.
- Uniformly distributed load of 0.7 kN/m applied in any direction along the top of the handrail.
- Uniformly distributed vertical load of 1.5 kN/m applied along the top of guard.
- Concentrated infill load of 0.5 kN applied anywhere within the guard.
- Uniform wind load of 0.96kPa applied anywhere within the guard.

The following structural components were evaluated:

1.1 Rail Elements

- End Post, Mid Post, Corner Post - See drawing "Peak® Cable Railing – Posts".
- Handrail – See drawing "Peak® Cable Railing – Railing Assembly".

- Base Rail – See drawing "Peak® Cable Railing – Railing Assembly".
- Cable and Cable Fitting - See drawing "Peak® Cable Railing – Railing Assembly".
- Picket and Base Rail - See drawing "Peak® Cable Railing – Railing Assembly".
- Stair End Post and Stair Mid Post - See drawing "Peak® Cable Railing – Stair Assembly".
- Stair Handrail – See drawing "Peak® Cable Railing – Stair Assembly".
- Cable and Cable Stair Fitting - See drawing "Peak® Cable Railing – Stair Assembly".

1.2 Connectors

- Stair Handrail Bracket – See drawing "Peak® Cable Railing – Stair Assembly".

The complete list of all components (including non-structural components) for the system is included in Appendix A.

2 Infill Elements

The Peak® Cable Railing consist of horizontal cables spaced at regular intervals to form the infill element below the top rail. The cables are described below:

- 1x19 stainless steel cable.

This review is based on information and drawings provided by Peak Products Manufacturing Inc. (Peak) for the elements listed above.

2.1 Stainless Steel Cable

Our analysis is based on the following information:

- Loads: Prescribed by the Canadian building codes listed in Section 1.0 Overview.
- Cable deflection: Complete in accordance with British Columbia Building Code 2018 and National Building Code Alberta Edition 2019 Part 9 Sentence 9.8.8.5 with reference to Australian National Construction Code 2022 Part 11.3 for the prescriptive requirement for cable tension and opening spreading load requirements.
- Resistance: Completed in accordance with CSA-S6 Canadian Highway Bridge Design Code Sentence 10.8.4
- Load configuration: Span and cable lengths were provided by Peak.

3 Rail Elements

3.1 General Rail Elements

The general rail elements include the rail element described in Section 1.1. An analysis was completed based on the worst-case configuration for these elements.

- Loads: Prescribed by the Canadian building codes listed in Section 1.0 Overview.

- Resistance: Completed in accordance with CAN/CSA S157-17 – Strength Design in Aluminum, and CSA A500-16 – Building Guards
- Section properties: Information was provided by Peak. Calculations were completed in accordance with CAN/CSA S157-17.
- Fastener resistance: Completed in accordance with CAN/CSA S16-2021, Design of Steel Structures
- Load configuration: Span and dimensions were provided by Peak. Posts were modeled as cantilevers, fixed at the base. The results from our analysis show the maximum span that can be achieved, as calculated from the material and fastener resistances.

4 Connectors

4.1 General Connectors

The general connectors include the stair handrail bracket. An analysis was completed based on the worst-case configuration for these elements.

- Loads: Prescribed by the Canadian building codes listed in Section 1.0 Overview.
- Resistance: Completed in accordance with CAN/CSA S157-17, Strength Design in Aluminum.
- Section properties: Information was provided by Peak. Calculations were completed in accordance with CAN/CSA S157-17.
- Connections to the base building are not included as part of this review, including but not limited to the rail and post connections.
- Load configuration: Span and dimensions were provided by Peak.

5 Results

A full set of calculations and results is presented in RDH's compiled engineering review package. The engineering package includes:

- Dimensioned drawings of each component, including extrusion drawings.
- Calculation sheets for the structural capacity of components listed in 1.0 Overview.

The above documents contain proprietary information, and as such, have not been included in this report.

6 Conclusion

The Peak® Cable Railing System meets the requirements within Part 9 of the British Columbia Building Code 2024, the National Building Code Alberta Edition 2023, and the National Building Code of Canada 2020. Limitations of compliance are defined in the assembly drawings presented in Appendix B and in Section 1 of this report.

Yours truly,

Reviewed by

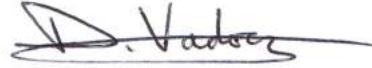

Matthew Cheong | EIT.
Structural Engineer-In-Training
mcheong@rdh.com
RDH Building Science Inc.

David Vadocz | P.Eng.
Principal, Façade Structural Specialist
dvadocz@rdh.com
RDH Building Science Inc.

- Encl. Appendix A – List of Components
- Appendix B – Assembly Drawings

Limits of Commission

This report was prepared for Peak. It is not for the use or benefit of, nor may it be relied upon, by any other person or entity, without written permission of RDH Building Science Inc.



Appendix A

List of Components

SKU (White)	SKU (Matte Black)	Description
93000	93001	END POST
93010	93011	MID POST
93020	93021	CORNER POST
93050	93051	STAIR END POST
93060	93061	STAIR MID POST
93100	93101	4' RAIL KIT
93110	93111	6' RAIL KIT
93130	93131	4'6" STAIR RAIL KIT
2954	2954	CABLE FITTING
2958	2958	CABLE STAIR FITTING
2962	2962	100' CABLE
2966	2966	500' CABLE

Appendix B

Assembly Drawings

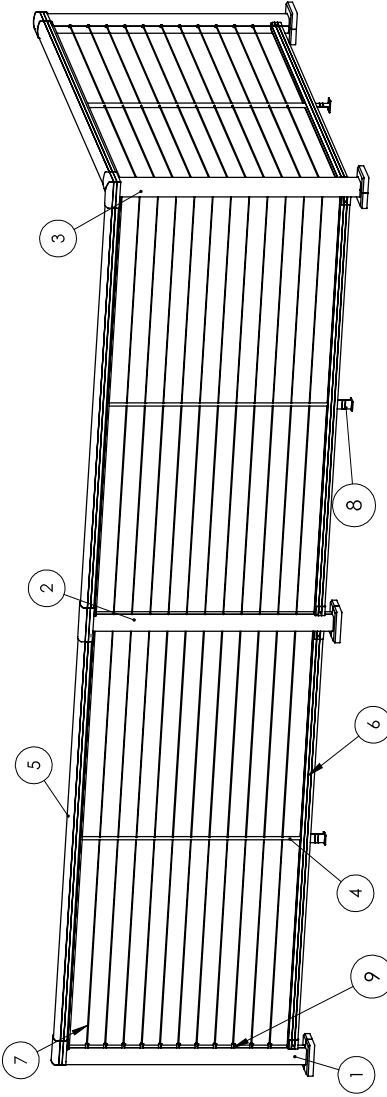
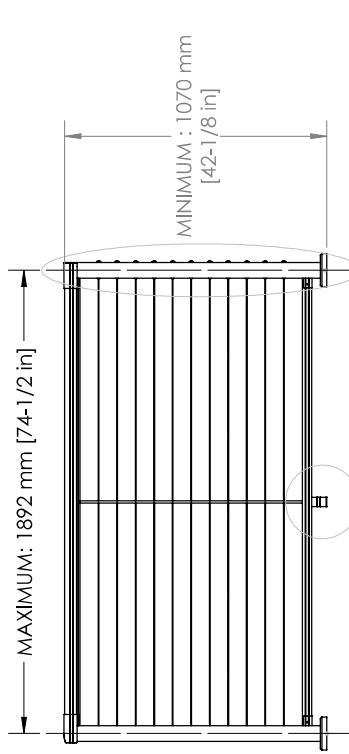
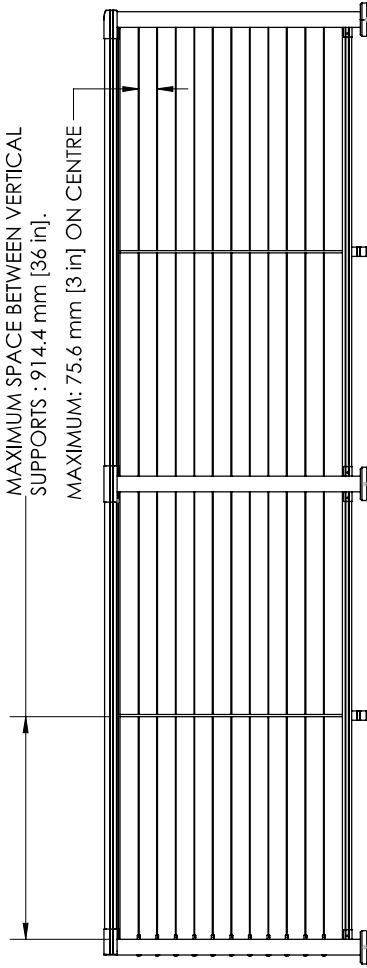

SEE DRAWING: POSTS
SEE DRAWING: BASE RAIL SUPPORT

IMPORTANT:

1. CABLE LENGTH: MAXIMUM 9.14 M [30 ft]
2. CABLE TENSION: MINIMUM 667 N [150 lbf]



Peak® Cable Railing
Railing Assembly

ITEM NO.	DESCRIPTION	SKU
1	END POST 42IN	93000, 93001
2	MID POST 42IN	93010, 93011
3	CORNER POST 42IN	93020, 93021
4	PICKET	93100, 93101, 93110, 93111
5	HANDRAIL	93100, 93101, 93110, 93111
6	BASERAIL	93100, 93101, 93110, 93111
7	CABLE	2962, 2966
8	BASE RAIL SUPPORT	93100, 93101, 93110, 93111
9	CABLE FITTING	2954

PART FILE
Report Drawing_Cable-Oct 2023

DWG REV
C

DIMENSIONS ARE IN MM UNLESS NOTED
DO NOT SCALE DRAWING

PROPRIETARY AND CONFIDENTIAL
THIS DRAWING AND ITS CONTENTS ARE PROPERTY OF THE ISSUING PEAK COMPANY (INCLUDING PEAK INNOVATIONS INC. AND PEAK PRODUCTS CORPORATION). ANY DISSEMINATION OR REPRODUCTION OR UNLICENSED USE IN WHOLE OR IN PART IS STRICTLY PROHIBITED.

SIZE
DWG. NO.

B Report assembly P9 Cables - 93XXX

SCALE: 1:32 5/16 REV
2017-05-16

SEE DRAWING: POSTS

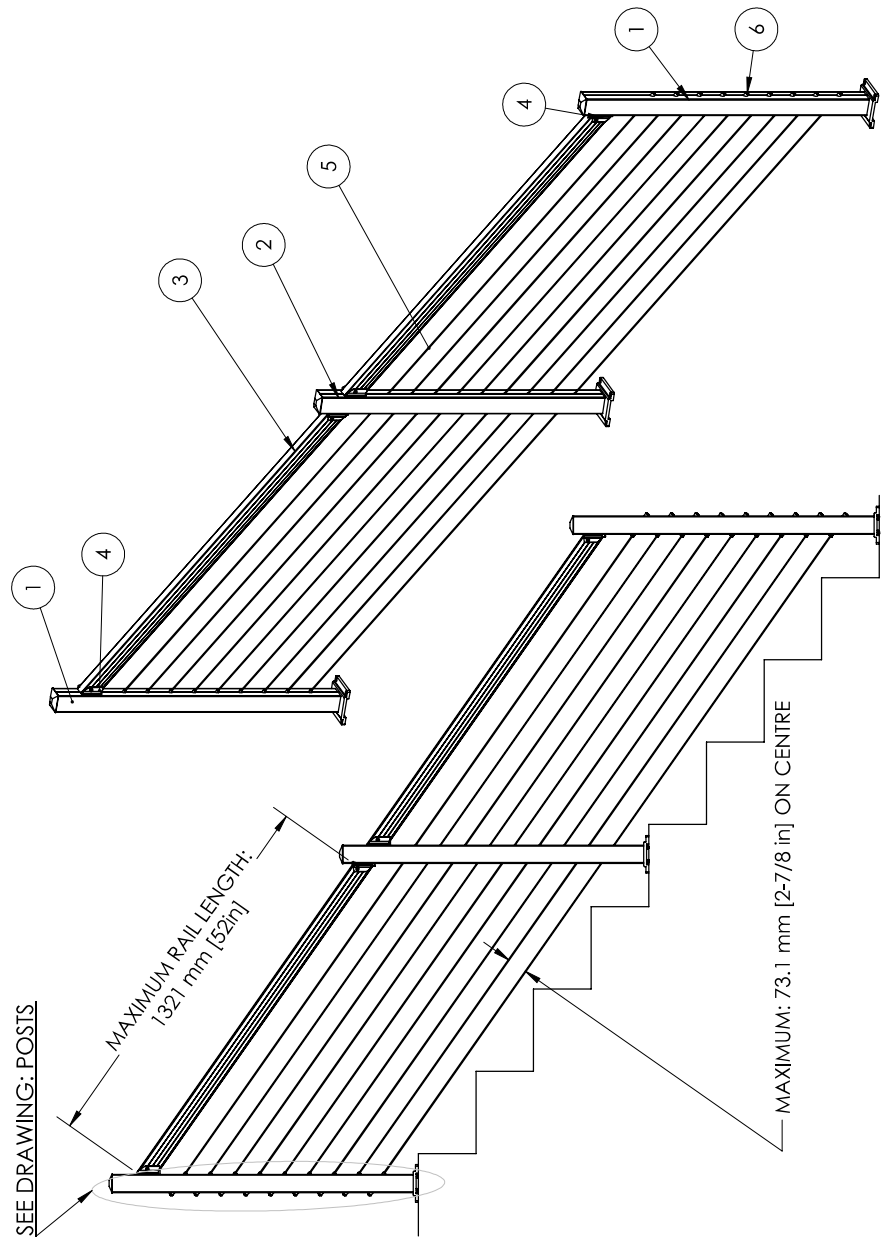

BRACKET MOUNTING TEMPLATE

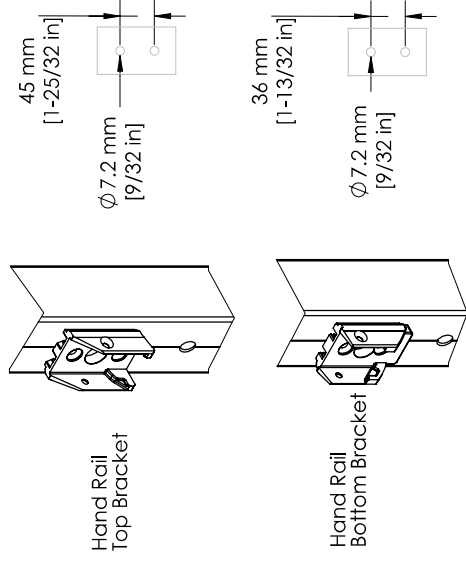

IMPORTANT:

1. CABLE LENGTH: MAXIMUM 9.14 M [30 ft]
2. CABLE TENSION: MINIMUM 979 N [220 lbf]



TITLE
Peak@ Cable Railing
Stair Assembly

PART FILE
Report Drawing_Cable-Oct 2023

DWG REV
C

DIMENSIONS ARE IN MM UNLESS NOTED
DO NOT SCALE DRAWING

PROPRIETARY AND CONFIDENTIAL
THIS DRAWING AND ITS CONTENTS ARE PROPERTY
OF THE ISSUING PEAK COMPANY (INCLUDING PEAK
INNOVATIONS INC. AND PEAK PRODUCTS
CORPORATION). ANY DISSEMINATION OR
REPRODUCTION OF UNLICENSED USE IN WHOLE OR
IN PART IS STRICTLY PROHIBITED.

SIZE
DWG. NO.

B
Report assembly P9 Cables - 93XXX

SCALE: 1:33,32017-05-16

ITEM NO.	DESCRIPTION	SKU
1	STAIR END POST	93050, 93051
2	STAIR MID POST	93060, 93061
3	HANDRAIL	93130, 93131
4	HANDRAIL BRACKET	93130, 93131
5	CABLE	2962, 2966
6	CABLE STAIR FITTING	2958

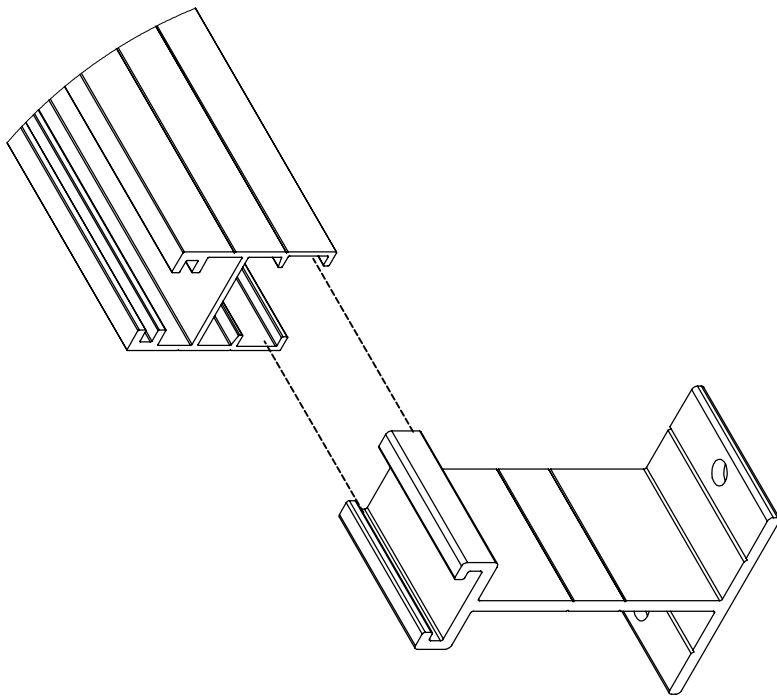

MOUNTING TEMPLATE:

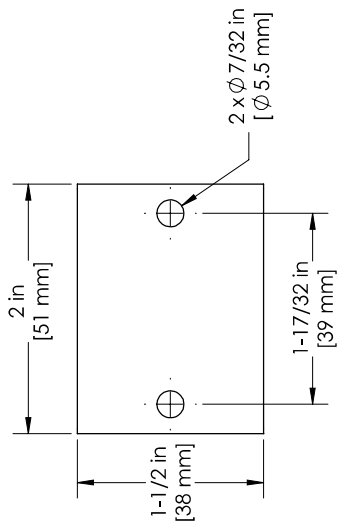

TITLE
BASE RAIL SUPPORT

PART FILE
Report assembly - base rail support -933XX

DWG REV
A
DIMENSIONS ARE IN MM UNLESS NOTED
DO NOT SCALE DRAWING

PROPRIETARY AND CONFIDENTIAL
THE INFORMATION CONTAINED IN THIS DRAWING IS THE SOLE PROPERTY OF PEAK. IT IS TO BE USED FOR THE PRODUCTION OF THE PART OR AS A WHOLE WITHOUT THE WRITTEN PERMISSION OF THE PEAK GROUP OF COMPANIES IS PROHIBITED.

SIZE
B DWG. NO.
Report Assembly - BASE RAIL SUPPORT - 933XX

SCALE: 1:1 SHEET NO. 2015-03-03-A Sheet 3 of 4

MOUNTING TEMPLATE

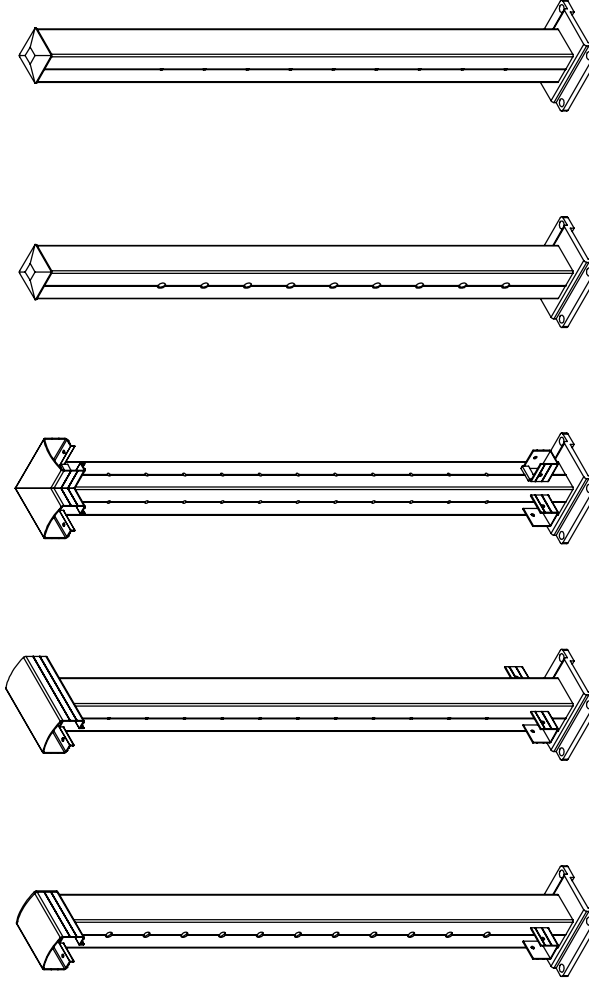
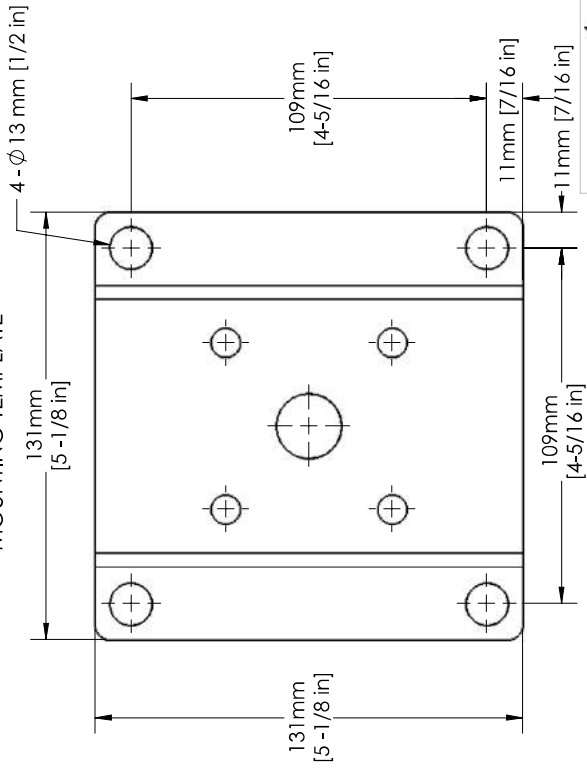

END POST
MID POST
CORNER POST
STAIR POST END
STAIR POST MID



Peak® Cable Railing Posts

PART FILE post-Base_10mm
DWG REV A

DIMENSIONS ARE IN MM UNLESS NOTED
DO NOT SCALE DRAWING

PROPRIETARY AND CONFIDENTIAL
THIS DRAWING AND ITS CONTENTS ARE PROPERTY
OF THE ISSUING PEAK COMPANY (INCLUDING PEAK
INNOVATIONS INC. AND PEAK PRODUCTS
CORPORATION). ANY DISSEMINATION OR
REPRODUCTION OR UNLICENSED USE IN WHOLE OR
IN PART IS STRICTLY PROHIBITED.

SIZE DWG. NO.
B Report Posts CAN P9 - 93k
SCALE: 1:8 5/16 REV 2017-05-16 Sheet 4 of 4

DESCRIPTION	SKU
END POST	93000, 93001
MID POST	93010, 93011
CORNER POST	93020, 93021
STAIR POST END	93050, 93051
STAIR POST MID	93060, 93061